

View A

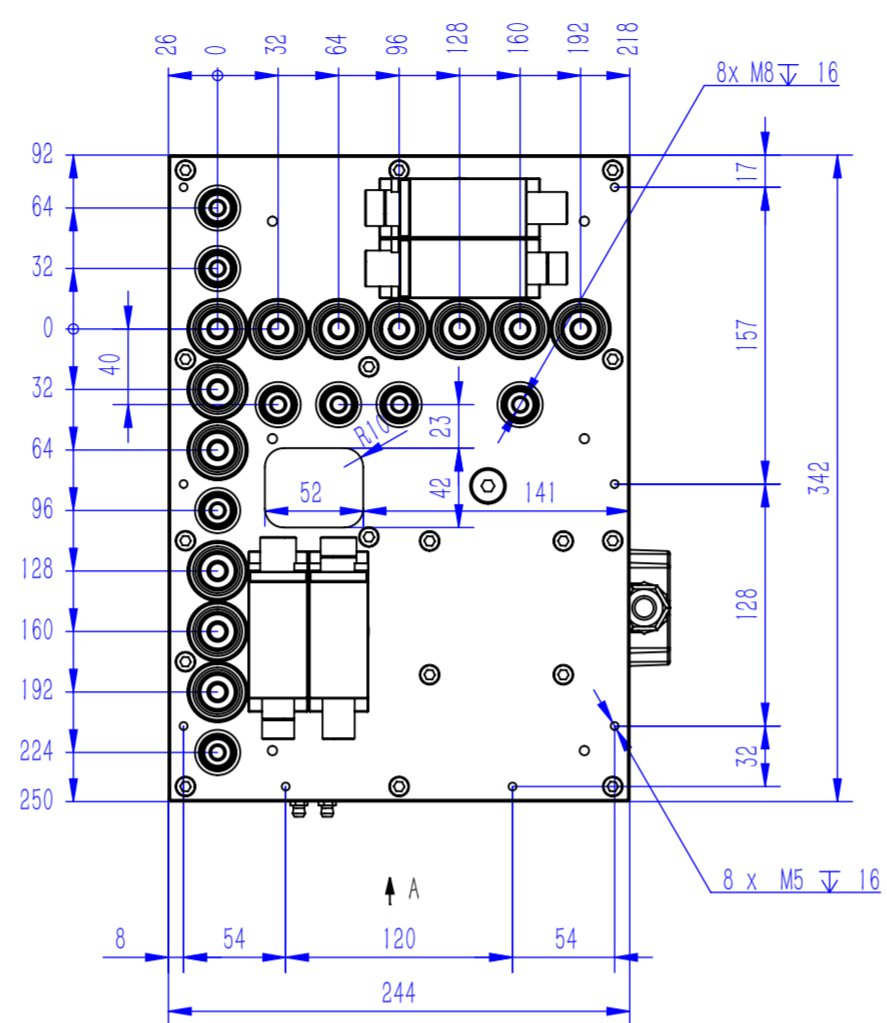

View B

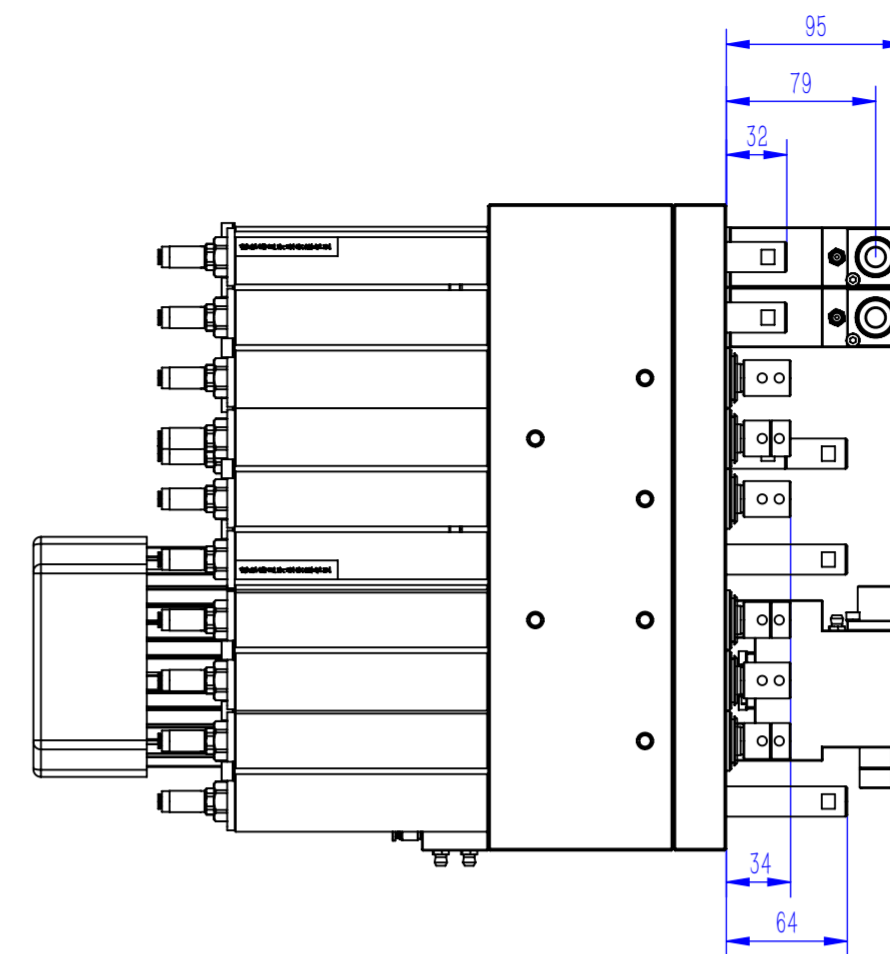

View C

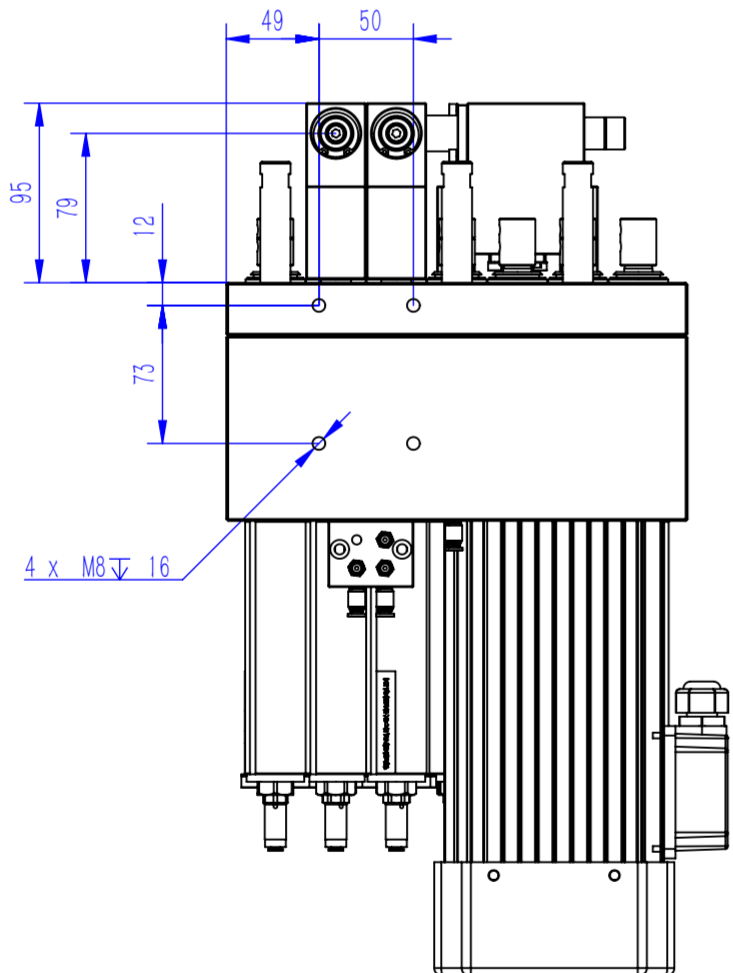

View D

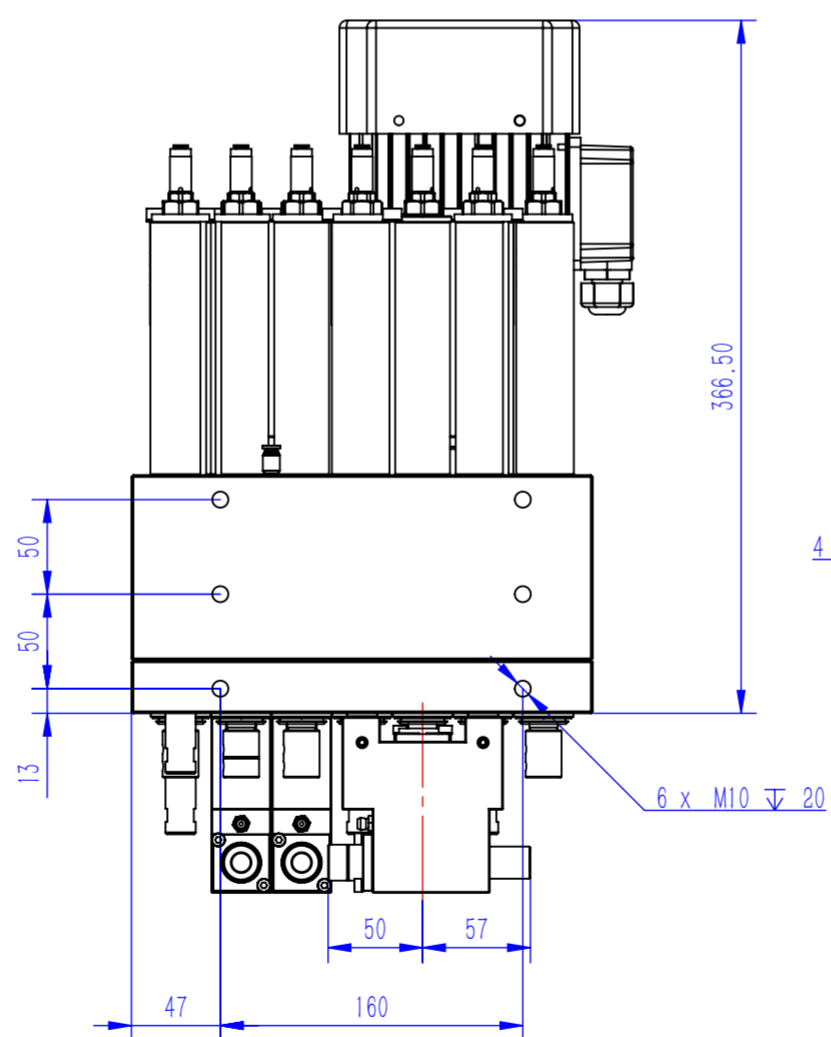

View E

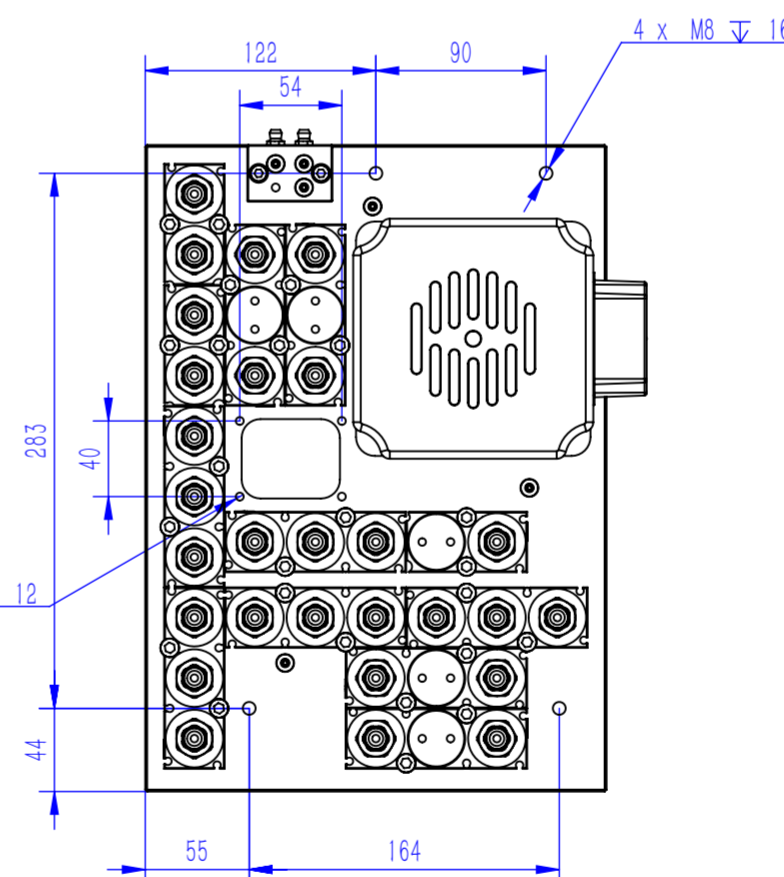

View F

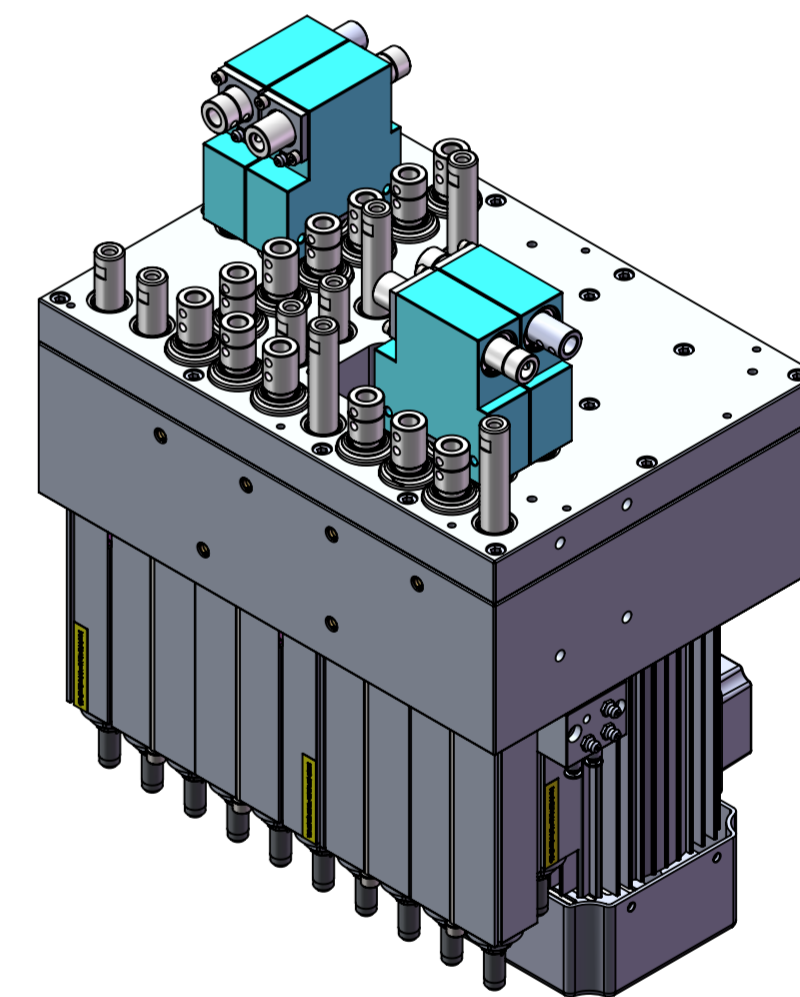

CNC Boring Heads parameters		Motor parameters		Jiangsu HQD spindle motor Co., Ltd
Vertical shaft speed	4500rpm	Motor power	3HP 2.2KW	
Horizontal shaft speed	4500rpm	Motor voltage	220/380V	
Stroke	68mm	Motor rated frequency	50/60Hz	PZ9H10A
Air pressure	0.65-0.8MPa	Motor rated speed	2800/3400rpm	
Lubrication grease	KLUBER ISOFLEX TOPAS L 32 N			V01
Tool interface	∅10mm	Installation depth	20mm	

Note: Please connect the motor for forward rotation but not reverse rotation. The shaft with scribed line is reverse rotation, and the shaft without scribed line is forward rotation. Please install the drill correctly.